

Specification Sheet

VT550 SWEEPER

Series VT550 Lite

Sheet 1 of 1

Subject Technical Information and Data

Issue Number: 07-08

Date: 19.08.08.

Reference: ED C/23497

Dimensions in mm

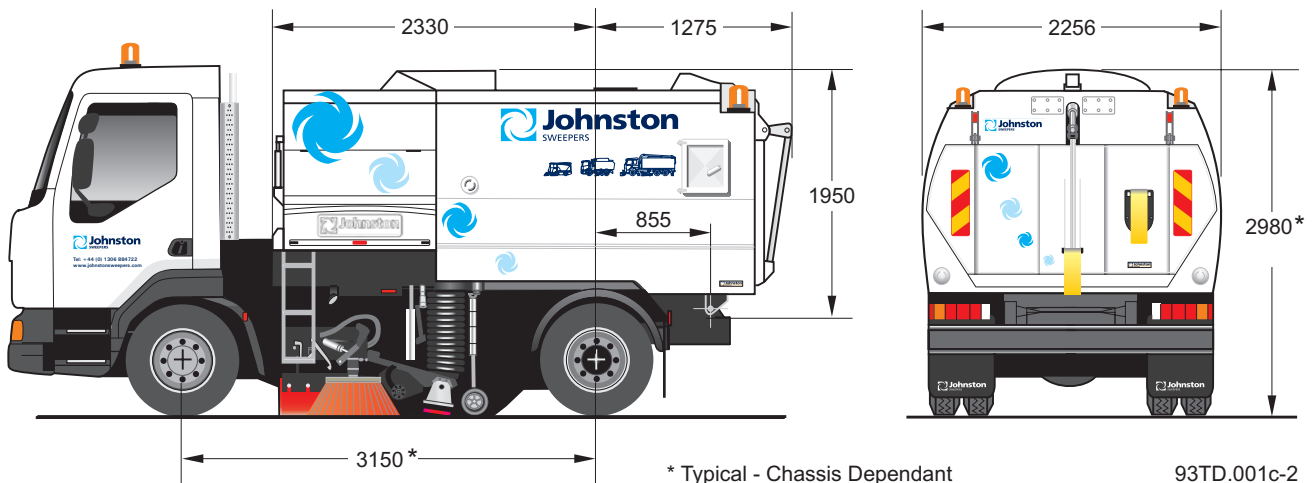

Data and Performance Information

Capacities	
Hopper voided volume	5.5m ³ nominal
Payload voided volume	5.0m ³ nominal
Payload capacity	2,030 Kg based on Daf 7.5 t E4 single sweep, less wide sweep brush
Fuel tank	100 litres
Water tank	980 or 500 litres selectable
Hydraulic system	55 litres

Engine Data	
Model	VMD754TE2
Cubic capacity	2.970 litres
Gross rated power	65kW @ 2300 rpm
Maximum torque	330Nm @ 1300 rpm
Legislation compliance	NRMM Tier 2 EC directive 97/68EC
Operational rpm	Variable between 1200-1800 rpm
Sump capacity	10 litres
Ambient temperature	46°C worldwide approval
Cold start capability	-15°C

Sweeping Equipment	
Channel brush (CB)	Ø 500mm
Wide sweep brush (WSB)	Ø 340mm
CB life expectancy	80 accumulated working hours (nom)
WSB life expectancy	150 accumulated working hours (nom)
Nozzle trunking diameter	Ø 250mm
Nozzle width	750mm

General Data	
Chassis requirement	7.5-10 Tonnes
Wheelbase	3150mm nominal
Dump height	950mm (nom) chassis dependant
Dump angle	55° nominal
Door opening angle	125° nominal
Filter mesh area	1.05m ²
Dust spray pump output	Up to 35 l/min
Dust spray water pressure	3.5 bar
Hydraulic suction filtration	125 micron
Hydraulic return filtration	25 micron
Hydraulic pump displacement	19 cc/rev. max output 34 litres

Johnston Sweepers Limited, Curtis Road, Dorking, Surrey RH4 1XF, UK
 Tel: +44 (0) 1306 884722 Fax: +44 (0) 1306 884151
 www.johnstonsweepers.com E-mail: enquiries@johnstonsweepers.com



Technical Specification

Aux Engine Powapack

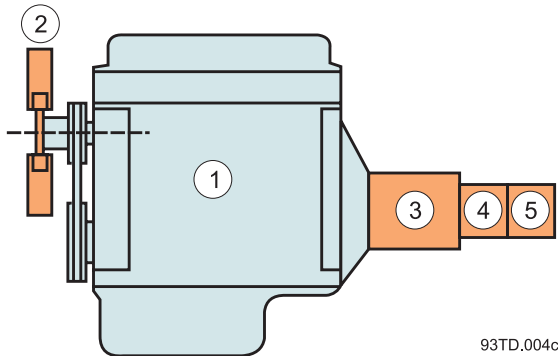

- 1 Engine
- 2 Cooling Fan
- 3 Fan Pump
- 4 Sweep System Pump
- 5 Water System Pump

93TD.004c

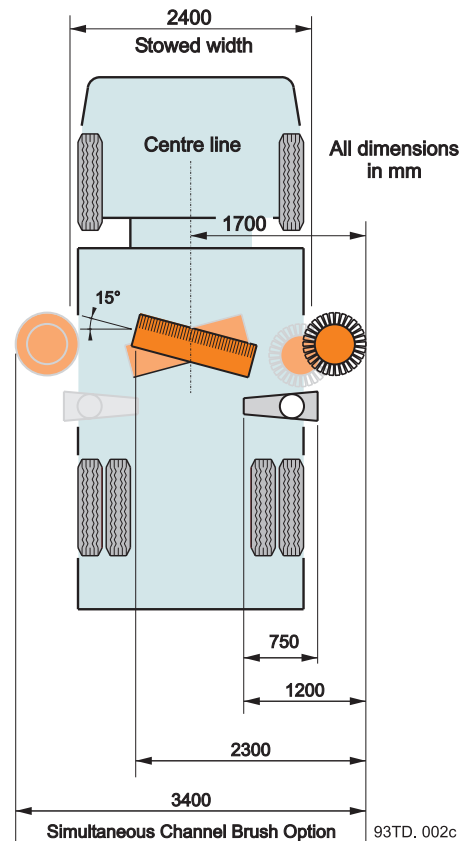

Base specification

Performance data

Exhauster fan:

Heavy duty, dynamically balanced impeller with multivane corrosion resistant blades. Operational speed variable between 2400 rpm - 3500rpm to suit operation. Hydrostatically driven from a variable displacement pump.

Channel brush:

Quick release brush system with variable speed up to 200rpm (cab controlled)

Nozzle:

Low noise suction system with 250mm diameter inlet, tool free adjustment.

Wide sweep brush:

Quick release brush system with a nominal 120rpm rotation speed.

Dust suppression system:

Dust suppression sprays located at suction nozzle(s), channel brush(es) and across front of vehicle.

Pressadrain water purging system.

Electrical system:

24 volt CANbus with diagnostics. All external loom connections are full automotive IP67 rated.

Controls:

Cab mounted master control panel with CANview for lamps, including:

- Raised hopper warning.
- Auxiliary engine hour counter.
- Fuel gauge.
- Low level lost water.
- Engine tachograph meter.
- Low level hydraulic oil indicator.
- Service interval.

In cab noise:

<75 dB(A) generally (dependent on chassis selection).

Exterior noise / Sound power level:

L_{WA} 108 dB(A) for turbocharged engine measured in accordance with EC directive 2000/14/EC.

Body

Comprises of hopper, integral water tank and engine cowl. Fabricated from heavy duty stainless steel plate.

Cowling and access doors are lined with frequency matched soundproofing material.

Water tank incorporates anti-surge baffles and filled via a type 'A' water hydrant fill.

Single point rear door latching system with water drain off. Two body side access doors.

Automatic multi position body propping mechanism (with manual retract).

Optional equipment examples

- Beacon cages.
- Dual sweep.
- Emergency discharge hand pump.
- Littasnatch.
- Powascrub - wide sweep brush ground pressure device.
- Powathrust/Powasave.
- Pneumatic filter mesh shakers.
- Separate diesel tank to serve auxiliary engine and chassis.
- Simultaneous sweep (both channel brushes operating at same time).
- Supawash - high pressure washing system 30 l/min @ 100 bar. Handlance, hose reel, front and nozzle spraybars.

NB: The addition of the various options will have an effect on the payload.

A comprehensive range of additional options is available. Please ask for details.

Johnston Sweepers Limited, Curtis Road, Dorking, Surrey RH4 1XF, UK
 Tel: +44 (0) 1306 884722 Fax: +44 (0) 1306 884151
 www.johnstonsweepers.com E-mail: enquiries@johnstonsweepers.com

